

Name: _____		Date: _____	Event: _____
City: _____		State: _____	
Track: _____			
Track Conditions	<input type="checkbox"/> Indoor <input type="checkbox"/> Tight <input type="checkbox"/> Smooth <input type="checkbox"/> Hard Packed <input type="checkbox"/> Blue Groove	<input type="checkbox"/> Wet <input type="checkbox"/> Grass <input type="checkbox"/> Low Bite <input type="checkbox"/> High Bite	
	<input type="checkbox"/> Outdoor <input type="checkbox"/> Open <input type="checkbox"/> Rough <input type="checkbox"/> Loose/Loamy <input type="checkbox"/> Dry	<input type="checkbox"/> Dusty <input type="checkbox"/> Astro Turf <input type="checkbox"/> Med Bite <input type="checkbox"/> Other _____	

Front Suspension

Toe: _____

Ride Height: _____

Camber: _____

Caster: 0° 5° Trail: 2mm 4mm

Kick Angle: 20° 25° 30°

Sway Bar: _____

Oil: _____

Piston: _____

Spring: Standard Low Freq. Color: _____

Front Pivot: Aluminum Plastic HRC

Kick Shim: Brass Plastic

Shock Limiters: _____

Shock Location: _____

Bump Steer Ball Stud: Standard Low Mount

Bumper Steer Spacers: _____

Ackermann Ball Stud: Standard Low Mount

Ackermann Spacers: _____

Camber Link: _____

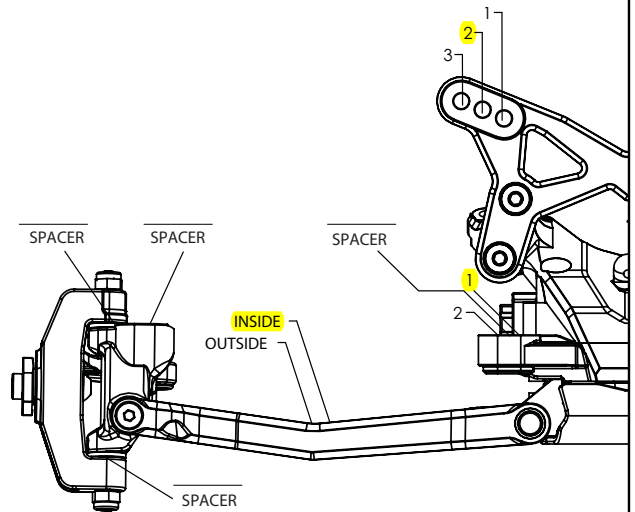

Notes: _____

Rear Suspension

Chassis Configuration: Rear Motor Mid Motor

Toe: _____

Anti-Squat: _____

Roll Center: Low Roll Center (LRC) High Roll Center (HRC)

Ride Height: _____

Camber: _____

Rear Hub Spacing: _____

Hex Width: _____

Sway Bar: _____

Oil: _____

Piston: _____

Spring: Standard Low Freq. Color: _____

Shock Limiters: _____

Camber Link: _____

Shock Locations: _____

Wing/Wickerbill: _____

Battery Position: _____

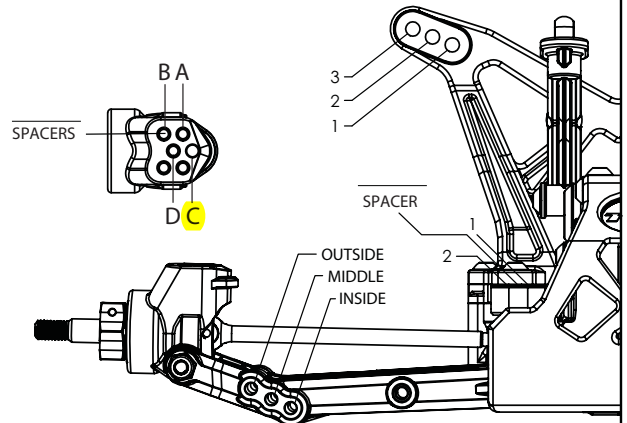

Electronics

Radio: _____

Servo: _____

ESC: _____

Initial Brake: _____

Drag Brake: _____

Throttle Profile: _____

Timing Advance: _____

Throttle/Brake Expo: _____

Servo Expo: _____

Throttle/Brake EPA: _____

Motor: _____

Pinion: _____ Spur: _____

Battery: _____

Weight Placement (Mark with "X")

Weight of each piece _____ oz./g

Tires

Compound _____

Insert _____

Additive _____

Front: _____

Rear: _____

Notes: _____